

Improving Motor Efficiency in Constant Speed Applications

by Christine Toledo

Learning Objectives

After reading this article, you should have learned about:

- ◆ AC motor
- ◆ how an AC motor works
- ◆ motor efficiency
- ◆ how “power factor” relates to the efficiency of a motor
- ◆ the kinds of losses present in a motor
- ◆ the benefits to saving energy, outside of reducing an energy bill
- ◆ how the efficiency of a motor is increased
- ◆ how motor efficiency can be increased without sacrificing performance
- ◆ other options for saving energy, and where they are applicable

Introduction

As early as the mid 1990s, the U.S. Department of Energy (DOE) recognized that electric motors consume roughly a quarter of all electricity in the U.S. and more than 60% of all electricity used by the manufacturing sector. Therefore, technology solutions that could be focused on electric motors could provide a major step toward demand reduction. Since motors are major users of electric power, it makes real sense to promote increased efficiency.

Most multistory buildings are deeply invested in reducing energy consumption. Whether it's something as simple as lighting-system motion or infrared sensors, or as complex as smart building controls that regulate the lighting and heating-ventilation-and-air-conditioning systems, most

buildings have some form of energy-savings programs. Until recently, elevators and escalators, for all intents and purposes, have been left out of the green-building process. The reasons for this vary – safety, convenience and ignorance of available options – but they all add up to the same thing: an inefficient AC motor that is crying out for an efficiency solution.

How Does an AC Motor Work?

Before discussing ways to improve efficiency in an AC motor, it's important to understand how they work. Although there are several different types of AC motors in use today, by far the most common is the asynchronous squirrel-cage type motor, with an external stator core inside of which the rotor rotates. The motor shaft is attached to the rotor, and the rotation of the shaft produces the useful work. Figure 1 shows an exploded view of a typical squirrel-cage induction motor. Figure 2 and Figure 3 show more-detailed depictions of the stator and rotor construction in a typical motor.

The stator is typically made up of multiple coils of copper wire that are inserted in slots of a laminated steel core. The number of coils (or poles) per phase determines the speed at which the rotor turns.

The rotor is typically made up of a number of coils (actually, since the currents are much higher in the rotor than the stator, these are usually copper bars) embedded in a laminated iron core.

When alternating current flows through the stator windings, the magnetic field created by the windings



Value: 1 contact hour

This article is part of ELEVATOR WORLD's Continuing Education program. Elevator-industry personnel required to obtain continuing-education credits can receive one hour of credit by reading the article and completing the assessment examination questions found on page 7.

For this article and more continuing-education opportunities, visit www.elevatorbooks.com



Approved by NAEC for CET



Approved by NAEC for CET



Approved by NAESAI for QEI

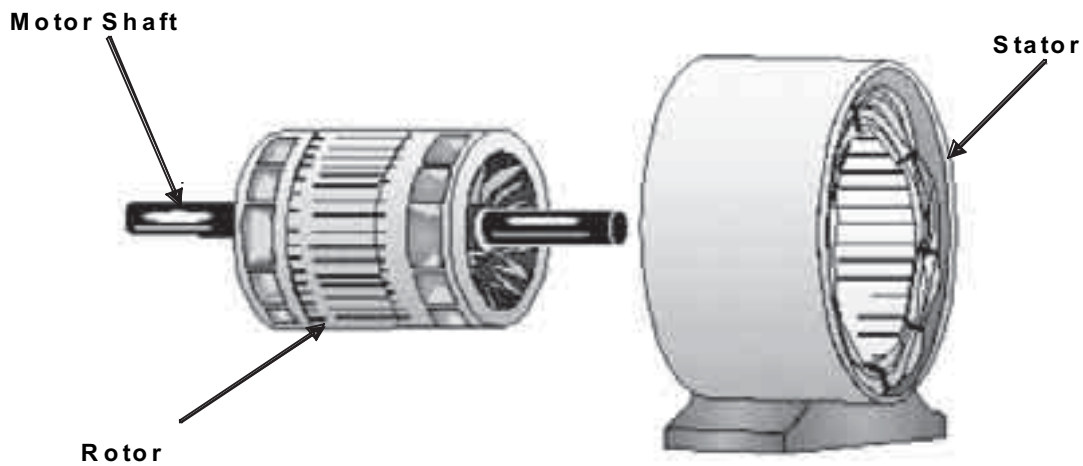

Figure 1

Stator Assembly

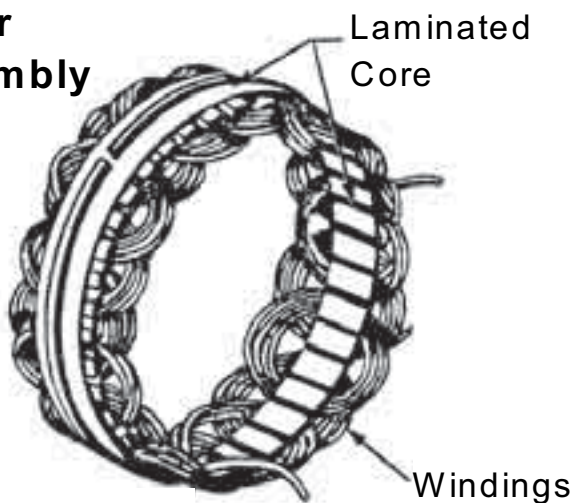

Figure 2

Rotor Assembly

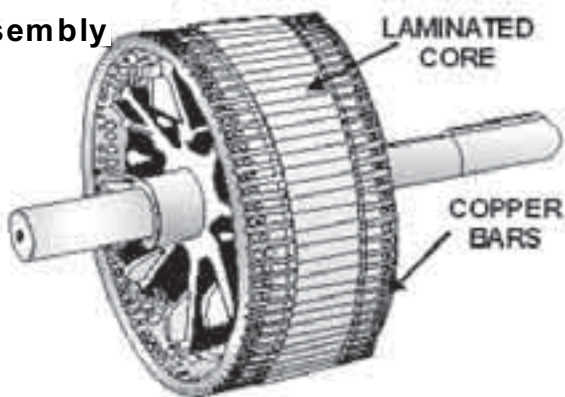

Figure 3

“rotates” around the stator body. The speed at which the magnetic field rotates is called the “synchronous speed” of the motor and is a multiple of the supply frequency (in Hertz) divided by the number of poles. The synchronous speed is determined by the following equation:

$$f_s = \frac{120 * f_{supply}}{\#ofPoles}$$

Equation 1

In turn, this magnetic field induces current to flow in the rotor windings, creating a magnetic field that is opposite in polarity to the stator magnetic field. As the stator magnetic field rotates, the rotor body rotates in the same direction, with the rotor magnetic field attempting to “catch up” to the stator field. If there were no load at all on the rotor and negligible losses, the rotor would rotate at negligible slip and very close to synchronous speed with the stator magnetic field. As the load on the rotor increases, the rotor speed falls behind the stator field. The magnetic field of the rotor cutting into that of the stator as it tries to catch up develops the torque required to keep the rotor (and its attached load) turning.

The differential in speeds is referred to as “slip,” and is simply the ratio of the difference between the synchronous (stator field) speed and the rotor speed to the synchronous speed:

$$Slip = \frac{(f_s - f_r)}{f_s}$$

Equation 2

where f_s is the synchronous speed and f_r is the rotor speed. This represents the magnetic flux cutting the rotor conductors as it slips, producing torque. The greater the load on the rotor shaft, the larger the slip and, therefore, the greater the torque produced.

In an unloaded motor, there is very little slip and very little torque produced. The motor is performing only a very small amount of useful work. Thus, the motor is operating at a very low efficiency. In a heavily-loaded motor, the slip is high (typically about 5%), most of the input energy total is used to move the load and the motor is operating very efficiently.

Motor Efficiency

In a perfect world, AC induction motors would operate at 100% efficiency – in other words, every kilowatt of power delivered to the motor terminals would be converted to useful work at the motor shaft. However, in the real world (the world in which most of us live), this is not the case. Only a percentage of the delivered power is converted to useful work, and that percentage will vary. The efficiency is the ratio of power delivered by the motor at the shaft to the power delivered to the motor at the terminals.

$$\text{Efficiency} = \frac{\text{useful power out}}{\text{total power input}}$$

Equation 3

In general, AC motors operate most efficiently at around 90% of full rated load, with the efficiency falling off only slightly until somewhere between 25% and 50% of full load, where the efficiency begins to drop significantly. As a rule of thumb, the larger the motor, the flatter this curve is, and the lower the load percentage has to drop before the efficiency starts to drop. The efficiency curve for typical AC motors is shown below:

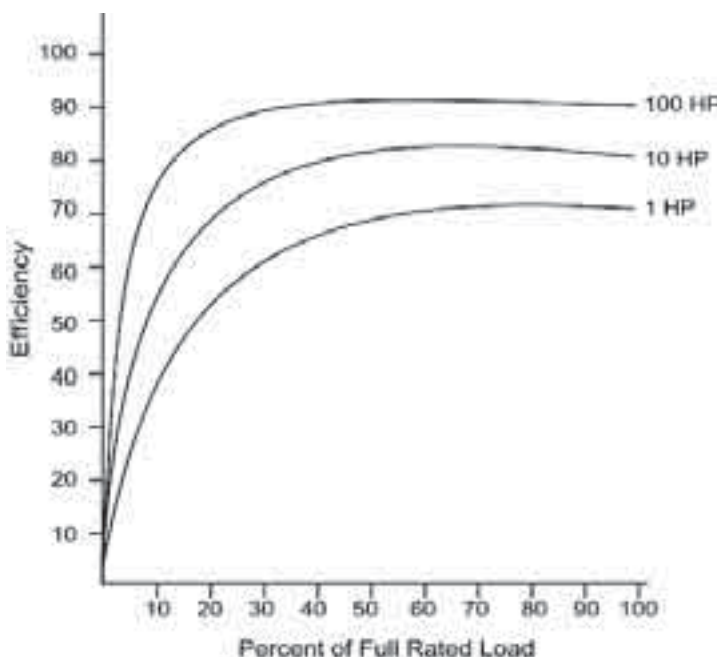

Figure 4

Power Factor

In a purely resistive AC circuit, voltage and current waveforms are in phase, changing polarity at the same instant in each cycle.

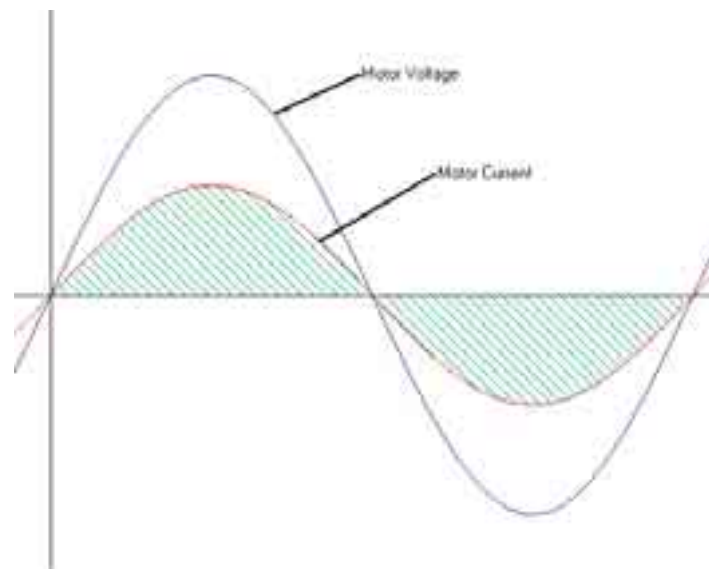

Figure 5

When reactive elements are present, such as capacitors or inductors (such as an AC induction motor), energy storage in these reactive elements results in a time difference between the current and voltage waveforms. With an inductive load, the current lags behind the voltage:

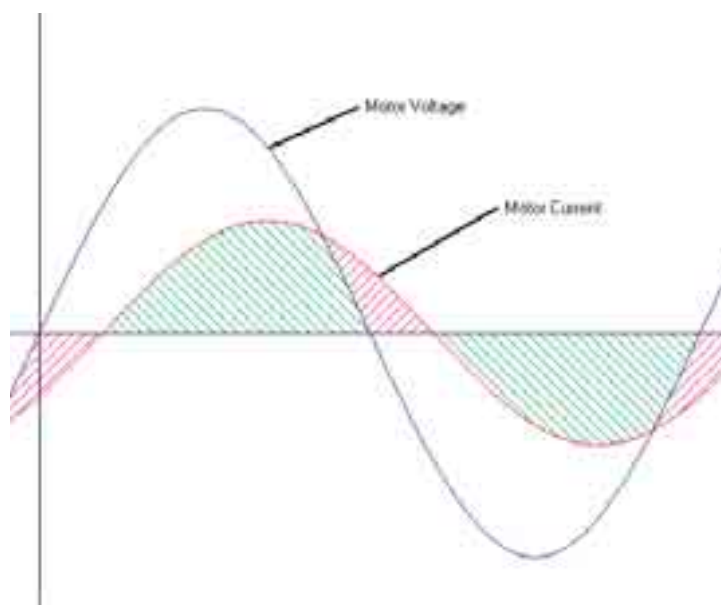

Figure 6

Since this stored energy returns to the source (the power company) and is not available to do work at the load, a motor with a low power factor will require more current draw to do a given amount of work than a motor

with a high power factor. In the graphs above, the green shaded region represents the period of time during which the current is doing useful work, and the pink shaded region represents the time when the current is merely being stored in the reactive elements and returned to the source.

AC power flow has three components:

- ◆ Real power (P), measured in watts (W), represented by the green shaded area in Figures 2 and 3
- ◆ Reactive power (Q), measured in reactive volt-amps (VAr), represented by the pink shaded area in Figure 3
- ◆ Apparent power (S), measured in volt-amps (VA), represented by the combination of the pink and the green areas

Real power is the capacity of the motor for performing work in a particular time. Due to reactive elements of the load, the apparent power, which is the product of the voltage and current in the circuit, will be equal to or greater than the real power. The reactive power is a measure of the stored energy that is reflected to the source during each alternating-current cycle.

The power factor can be expressed as: $\frac{P}{S}$

In the case of a sinusoidal waveform (as in Figures 2 and 3), P , Q and S can be expressed as vectors that form a triangle such that:

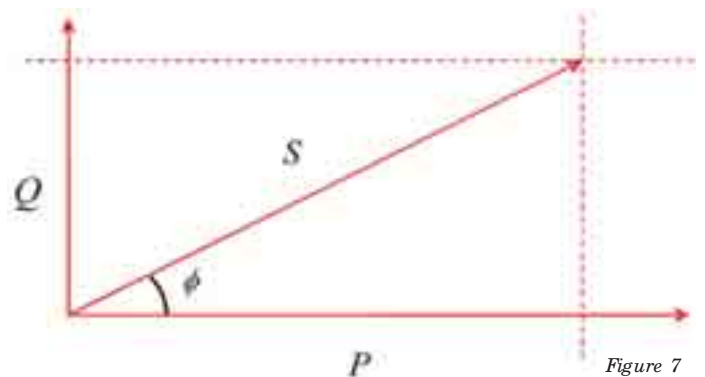

Figure 7

and:

$$S^2 = P^2 + Q^2$$

Equation 4

If ϕ is the phase angle between the current and voltage, then the power factor is equal to

and:

$$|\cos\phi| \quad P = S * |\cos\phi|$$

Equation 5

By definition, the power factor is a dimensionless number between 0 and 1. When power factor is equal to 0, the energy flow is entirely reactive, and stored energy in the load returns to the source on each cycle. When the power factor is 1, all the energy supplied by the source is consumed by the load. Power factors are usually stated as “leading” or “lagging” to show the sign of the phase angle.

For example, to get 1 kW of real power if the power factor is unity, 1 kVA of apparent power needs to be transferred (1 kVA = 1 kW x 1). At low values of power factor, more apparent power needs to be transferred to get the same real power. To get 1 kW of real power at an 0.2 power factor, 5 kVA of apparent power needs to be transferred (1 kW = 5 kVA x 0.2).

The Relationship between Power Factor and Motor Efficiency

While power factor and efficiency are not directly related (i.e., there is no equation that will solve for efficiency given power factor or vice versa), there is a physical correlation between the two.

In an unloaded motor, there is very little slip and very little torque produced. The motor is performing only a very small amount of useful work. Thus, the motor is operating at a very low efficiency. In a heavily-loaded motor, the slip is high (typically about 5%), most of the input energy is used to move the load and the motor is operating very efficiently.

As for power factor, an unloaded motor is similar to a transformer with no resistive load on the secondary. Little resistance is reflected from the secondary (rotor) to the primary (stator). Thus, the power line sees a reactive load with a power factor as low as 0.1 (10%). As the rotor is loaded, an increasing resistive component is reflected from rotor to stator, increasing the power factor. We can, therefore, use the power factor as an indicator of how large the load is (as a percentage of rated load) and how efficiently the motor is operating.

What Makes a Motor Inefficient?

There are essentially five contributors to power losses in an AC induction motor: friction loss, windage loss, sound loss, copper loss and iron loss. The first three (friction, windage and sound) are mechanical losses, are fairly constant and generally represent a very small fraction of the total wasted or lost power.

The copper loss is basically the energy lost to heat in the windings and is a function of the load. The iron loss is the energy lost due to eddy currents and hysteresis effects in the magnetic iron cores of the stator and rotor, and is a function of the voltage at the motor terminals – it is independent of the load. A motor is operating most efficiently when the iron loss and the copper loss are equal, which occurs when the motor is driving around 75-90% of the full rated load. As the load increases, the copper loss dominates. When the load is very low, the iron loss dominates, representing most of the energy loss.

Why Is It So Important to Improve the Efficiency of Motors?

Electric motors play a significant role in our energy problems. They are the true workhorses of our industrial and commercial facilities, consuming roughly a quarter of all electricity produced in the U.S. and more than 60%

of all electricity used in industrial facilities. The most energy-intensive sector in the U.S. is the manufacturing sector. A recent U.S. DOE study determined that 44% of industrial motors operate consistently at less than 40% of full load.

The key to saving energy on electric-motor operations is by implementing energy-management practices or applying energy-efficient technologies.

“... the cheapest and most available source of new energy is the energy we waste,” explained U.S. Energy Secretary Samuel Bodman. “That’s why we at DOE are always looking for ways to promote energy savings.”

What Are the Benefits of Saving Energy?

- ◆ **Cutting Electricity Costs:** In 2005, the nation’s energy bill totaled US\$296 billion. According to the U.S. DOE, a typical industrial facility can realize savings as much as 18% in motor systems. Investing in energy-efficiency technologies will help bring electricity costs down and reduce the number of new power plants needed. Companies affected by rising electricity costs would see an increase in their bottom lines as energy efficiency improves.
- ◆ **Receiving Utility Rebates:** Many utilities offer rebates to customers on energy-efficient technologies and equipment installed in their facilities. Utility rebate and incentive programs are designed to facilitate the implementation of energy-efficiency improvements. This encourages electricity customers to use energy-saving technologies to cut energy usage, which will help lower the demand for electricity and reduce the number of new power plants needed.
- ◆ **Reducing Carbon Emissions:** With increasing concern about greenhouse gases and climate change, we need to take responsibility and realize that carbon-dioxide emissions are polluting our environment and causing the effects of global warming. When we use less energy, the result is less pollution. Reducing carbon emissions through the use of energy-efficiency technologies can make a substantial impact on our environmental challenges.

What can we glean from the above? First, there are quite a few motors in the field that are operating well below optimum efficiency, wasting a considerable amount of energy in the process. Second, there are a number of valid reasons for reducing the amount of energy consumption, and reducing wasted energy is basically the “low-hanging fruit.”

Increasing the Efficiency of a Motor

As we have shown above, the efficiency of a motor is simply the ratio of the power out (useful work performed) to the power in (electrical power delivered to the motor terminals). Thus, the only ways to increase the efficiency of a motor are to reduce the losses or to use more of the input power to do useful work.

While it is certainly possible to reduce the mechanical losses in a motor (better lubricants and bearing systems, streamlined motor designs to reduce windage, reduction

of vibration noise, for instance), since these losses represent only a tiny fraction of the total losses, it is difficult to cost effectively do so. However, these are some of the techniques used to produce National Electrical Manufacturers Association (NEMA) premium efficiency motors (which helps explain the usually significant cost difference between premium- and standard-efficiency motors).

Reducing the copper losses (also known as I²R losses, as the power lost to heat is proportional to the resistance of the conductor as well as the square of the current) can be achieved by using larger conductors (quite expensive with the price of copper today) or reducing the current by switching to a higher mains voltage. This is usually not feasible since the mains voltage level is primarily fixed by the location.

Reducing the iron-core losses is accomplished by use of different materials and construction techniques. The magnitude of the eddy currents is significantly reduced by use of a core that is made up of many thin layers laminated together, rather than a single monolithic core. Hysteresis effects are reduced by choice of laminate material.

Taken together, all of these measures will certainly reduce the losses significantly. Whether they are cost effective is a different story.

However, as noted above, efficiency can also be improved by ensuring that more of the input power is used to do real work. We have also noted that a motor operates most efficiently when the load on the motor is around 75-90% of the rated load for the motor. There are a number of ways to accomplish this.

The Power Switch

There is no better way to conserve energy than to simply shut off an idling motor. However, this is not always an option.

Sizing the Motor Correctly

If the driven load is fairly constant, one can simply install a motor that is matched to that load. In fact, the U.S. DOE recommends replacing oversized motors with smaller motors sized for the load. However, there are many cases where this is not possible, because the motor is sized to accommodate a much larger peak load, however infrequently that load occurs. Escalators are a perfect example of this – the motor is sized to accommodate a completely full escalator (which almost never occurs).

Variable-Frequency Drives

In certain applications, particularly those in which it is desirable to change the speed of the motor, variable-frequency drives (VFDs) can save energy. VFDs have been used on elevator and escalator motors in Europe and Asia, and the concept of slowing (or stopping) an escalator when it’s not in use (somewhat like a PC monitor’s screensaver) has some support in the U.S. However, VFDs suffer from several things that make them less than desirable in escalator applications.

First, in North America at least, changing the speed of an escalator violates code (specifically, ASME A17.1/ CSA B44). Even if it were to be allowed in a future version of this standard, the likelihood of a successful lawsuit the first time someone “got knocked down when the escalator suddenly sped up” would deter many from implementing this.

Second, it requires some means of sensing when a passenger is approaching, along with enough room for a corridor (or a gate/ turnstile) to prevent passengers from stepping on the escalator before it is up to full speed.

Finally (and this applies to any application, not just escalators), VFDs generally require more expensive, inverter-duty rated motors (or additional equipment) to ensure that the motor can operate properly and safely at reduced speeds. The standard NEMA Design B motors that are most common are not designed to operate at anything other than the standard supply frequencies of 50 or 60 Hz, and extended operation at lower speeds can cause the motors to overheat fairly rapidly. In addition, many of the least expensive VFDs commercially available require additional filtering (which is why they are inexpensive).

Motor Efficiency Controller (MEC)

The MEC is an energy-saving motor controller from Power Efficiency Corp. that constantly monitors the phase lag and reduces the voltage at the motor terminal to compensate. By reducing the voltage, we reduce the current, particularly the magnetizing current that contributes the most to the losses in a lightly loaded motor.

Most of us are familiar with Wye-Delta (or Star-Delta) starters. The principal behind these is that by reducing the voltage to 57% of full supply (dividing by the square root of 3), we reduce the current and torque to the square of that, or 1/3 of what you’d see at full voltage. The MEC family performs the same function, except that it is continually monitoring the phase lag and reducing the voltage to the minimum value required to produce only the torque required to run the load. The MEC effectively “right sizes” the motor on a real-time basis, consuming only the energy required to run the motor most efficiently at any given moment.

Which Option is Most Effective?

There really is no universally “best” solution, nor are all of the solutions mutually incompatible (the power switch will work with all the others just fine). However, for constant-speed applications such as escalators and elevators, the MEC offers a solution that conserves energy without sacrificing performance. Since they do not change the speed of the motor, they will work with any squirrel-cage motor without modification. Since they monitor the power requirements in real time, they don’t require “advanced notice” of a load change (something required for using the power switch as an “energy-saving device” or using a VFD on an escalator). Since they are capable

of delivering full power on demand, they essentially offer the right size of motor for a given load, eliminating the need to compromise performance at higher loads while still saving energy at reduced loads. Because the power savings increases as the load decreases, reduced-voltage controllers offer more savings than a NEMA premium efficiency motor in lower load conditions. Finally, unlike power switches and NEMA Premium Efficiency motors, reduced-voltage controllers incorporate native solid-state reduced-voltage starter (soft-start) capabilities, eliminating the need for a dedicated soft-start device.

Conclusion

There is no best energy-saving solution for all applications; indeed, having options is better than any single solution. It’s very critical today for facility owners and managers to be aware of new energy-efficiency technologies for electric motors. These new technologies can make a difference in our environment and offer multiple benefits to end users. Investing in these technologies uncovers opportunities for reducing energy usage and costs, while also maintaining and/ or increasing productivity. Improving efficiencies in electric motors also helps reduce maintenance costs, improve reliability of equipment and minimize unscheduled downtime. Being aware of what is available, having the knowledge of how these technologies work and understanding what is most appropriate for a certain application is taking a step toward planning what is best for any facility that has made it a priority to become more energy efficient.

Christine Toledo is the Marketing Communications manager for PEC

Learning-Reinforcement Questions

Use the below learning-reinforcement questions to study for the Continuing Education Assessment Exam are available online at www.elevatorbooks.com or and page 1 of this issue.

- ◆ What are the two main components to an AC induction motor?
- ◆ What is the “synchronous speed” of an AC induction motor?
- ◆ How is “slip” defined, and how does it relate to the efficiency of an AC induction motor?
- ◆ What are the five main contributions to energy loss in an AC induction motor?
- ◆ What are the three main benefits to improving the efficiency of AC induction motors?
- ◆ What are the most common methods for improving the efficiency of motors?
- ◆ What are the major drawbacks to changing the speed of a motor in an escalator?



ELEVATOR WORLD Continuing Education Assessment Examination Questions

Instructions:

- ◆ Read the article “Improving Motor Efficiency in Constant Speed Applications” (page 1) and study the learning-reinforcement questions.
- ◆ To receive **one hour** of continuing-education credit, answer the assessment examination questions found below online at www.elevatorbooks.com or fill out the ELEVATOR WORLD Continuing Education Reporting Form found overleaf and submit by mail with payment.
- ◆ Approved for Continuing Education by NAEC for CET and CAT, and NAESAI for QEI.

1. In the most common AC Induction motor, the “Squirrel Cage” construction consists of:
 - a. An external stator that rotates around a central rotor
 - b. An external rotor that rotates around a central stator
 - c. An internal rotor that rotates inside of an external stator
 - d. An internal stator that rotates inside of an external rotor
2. The synchronous speed of an AC induction motor is defined as:
 - a. The speed at which the shaft rotates
 - b. The speed at which the rotating magnetic field moves in the stator
 - c. The supply voltage frequency
 - d. None of the above
3. The synchronous speed of a 4-pole squirrel cage motor running off of a 460V 60Hz supply is _____.
 - a. 1800 rpm
 - b. 3600 rpm
 - c. 1725 rpm
 - d. 13,800 rpm
4. The slip of a heavily loaded motor is typically _____.
 - a. Close to zero.
 - b. Around 5%.
 - c. Around 95%
 - d. Around 1%
5. Which of the following is not a major contributor to inefficiency in an AC induction motor:
 - a. Copper loss
 - b. Iron Loss
 - c. Friction
 - d. Carbon loss
6. In a lightly loaded motor, the _____ is the main contributor to the motor’s inefficiency?
 - a. Iron loss
 - b. Slip
 - c. Apparent power
 - d. Torque
7. What are the primary drawbacks to using a VFD on an escalator motor?
 - a. Violates code
 - b. Generally requires a special motor
 - c. Requires additional sensors
 - d. All of the above
8. An AC induction motor operates most efficiently at _____ of full rated load?
 - a. 50%
 - b. 90%
 - c. 100%
 - d. 125%
9. Reducing the voltage at a motor’s terminals to 57% of full rated voltage will reduce the current and torque to _____ what they would be at full voltage.
 - a. 1/3
 - b. 3 times
 - c. 25%
 - d. 100%
10. For a constant speed, variable load application such as an escalator or an elevator, the best option for increasing efficiency of a motor is:
 - a. Power switch
 - b. MEC
 - c. VFD
 - d. A NEMA Premium Efficiency motor

ELEVATOR WORLD
Continuing Education
Reporting Form



Article title: "Improving Motor Efficiency in Constant Speed Applications" (EW, October 2007, page 88).

Continuing-education credit: This article will earn you one contact hour of elevator-industry continuing-education credit.

Directions: Select one answer for each question in the exam. Completely circle the appropriate letter. A minimum score of 80% is required to earn credit. You can also take this test online at website: www.elevatorbooks.com.

Last name: _____
 First name: _____ Middle initial: _____
 CET®, CAT® or QEI number: _____
 Company name: _____
 Address: _____ City: _____
 State: _____ ZIP code: _____
 Telephone: _____ Fax: _____
 E-mail: _____

This article, "Improving Motor Efficiency in Constant Speed Applications," is rated for one contact hour of continuing-education credit. Certification regulations require that we verify actual study time with all program participants. Please answer the below question.

How many hours did you spend reading the article and studying the learning-reinforcement questions?
 hours _____ minutes _____

Circle correct answer

- | | |
|------------|-------------|
| 1. a b c d | 6. a b c d |
| 2. a b c d | 7. a b c d |
| 3. a b c d | 8. a b c d |
| 4. a b c d | 9. a b c d |
| 5. a b c d | 10. a b c d |

Signature: _____

Payment options:

Check one: \$30.00 – Non-subscriber course fee
 \$25.50 – ELEVATOR WORLD subscriber course fee
 Subscriber #: _____
 (6 digit number on your print label or in your digital confirmation.)

Payment enclosed
 (check payable to Elevator World, Inc.)

Charge to my: VISA
 MasterCard
 American Express

Card number: _____

Expiration date: _____

Signature: _____

To receive your certificate of completion using the mail-in option: Send the completed form with questions answered and payment information included to: Elevator World, Inc., P.O. Box 6507, Mobile, AL 36660.

To receive your certificate of completion online, visit website: www.elevatorbooks.com and follow the instructions provided for online testing.

You now have the opportunity to earn Continuing Education contact hours in ELEVATOR WORLD magazine. Articles pertain to various industry topics which appear in the magazine bi-monthly and for every exam you successfully complete you'll earn 1-3 contact hours.

As a subscriber, you not only have full access to these Continuing Education articles, but you also receive 15% off of the retail price.

Your subscription & all Online Continuing Education Courses can be purchased at

elevatorbooks.com
ELEVATOR WORLD'S ONLINE BOOKSTORE

Your Subscription to
ELEVATOR WORLD
 has just become more valuable.